

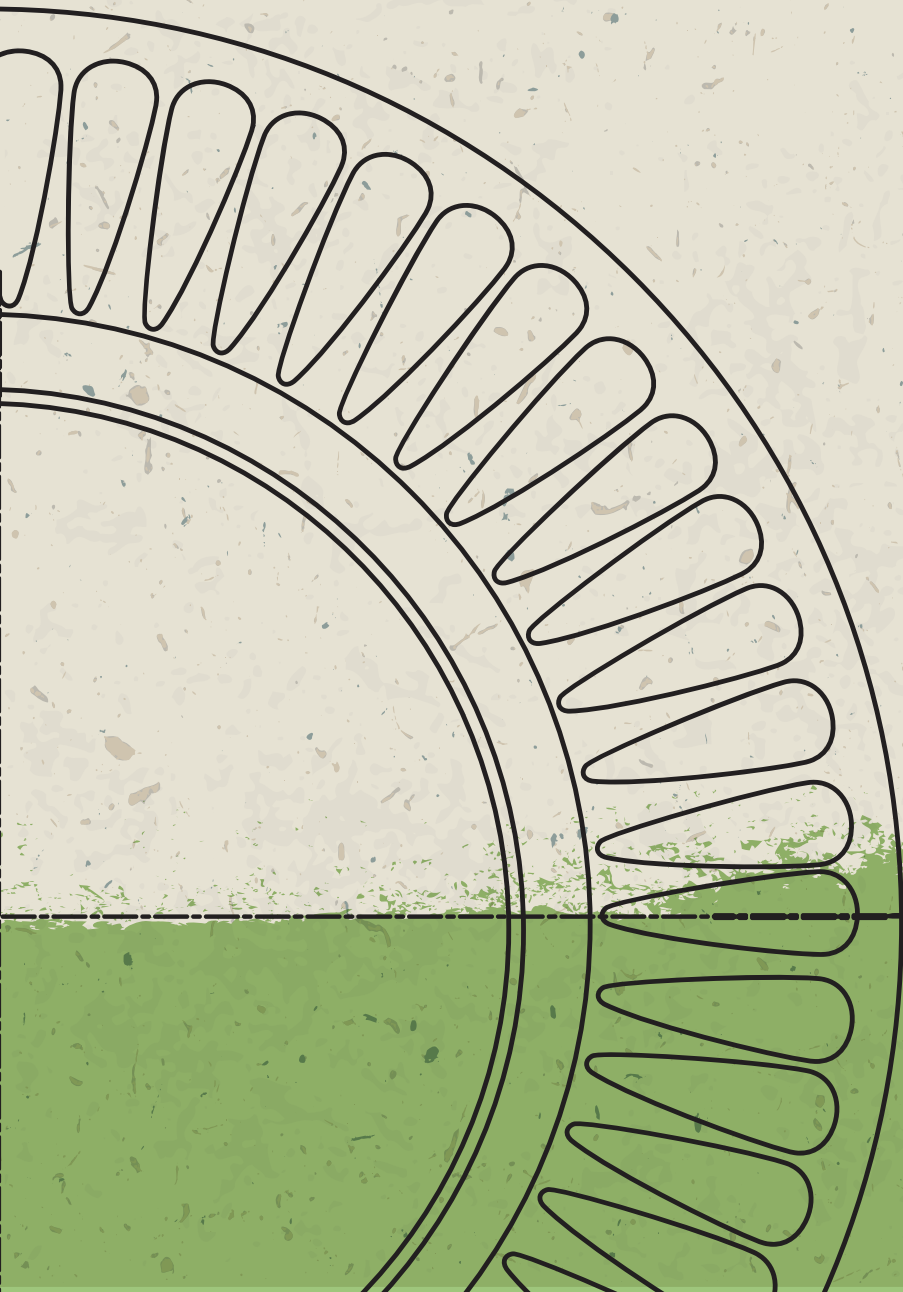

MULTIPAK

Environmentally friendly products will save the future.





“Produces eco-friendly products that protect the future!”



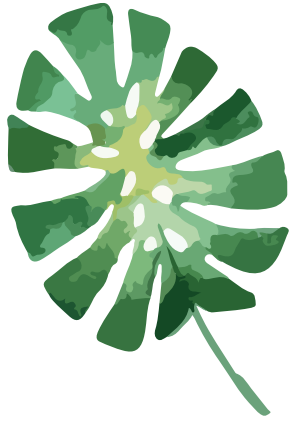

WE INSPIRE!

- Behind our meticulousness in the production of paper plates, cups, cake baking capsules and baking molds, there is our determination to produce products not harming the environment and human health!
- This determination enables us to stand firmly behind our quality standards and words.
- The trust and point of view that we have developed made us the brand of inspiration for the sector in a short time.

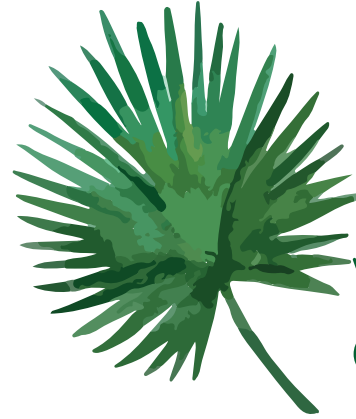

WE ARE CREATIVE!

- We offer aesthetic and functionality with eco-friendly raw materials.
- Along with our innovative ideas under a single roof, we are creative thanks to our production capability in different fields!

The world was full of undiscovered potential, and people have lived by convincing themselves in the infinity of resources since the world began. At this point, we will either adopt better and sustainable lifestyles or just watch our extinction.

As Multipak, we have been producing in order to support sustainable life since it was founded. We are proud to fulfill all the conditions of being a

“eco-friendly brand”

in all our processes starting from the use of raw materials!

As well as contributing to a healthier planet, we are glad to grow rapidly in the local and European market with the eco-friendly strategies we have developed.

We draw our strength from our respect for the perfect functioning of nature.

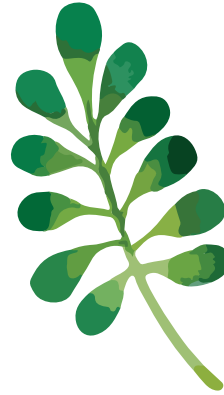

**WE ARE
ECO-
FRIENDLY!**

- **Instead of obtaining raw materials required by the industry from existing trees, we supply from industry from forests.**
- **We produce 100% renewable products, the raw materials of which are cellulose, semi-cellulose and lignin, which are completely degraded by microorganisms in nature.**
- **We contribute to the protection of human health, water resources and nature.**

INSPIRED
BY NATURE!





produces
eco-friendly
products that
protect the
future!

Takes firm steps forward with its
8000 m²
production facility established in
Torbalı, Izmir on a
16.500 m² area,
70 m² showroom and
135 qualified personnel in total.

Multipak, one of Europe's industry-leading three companies, maintains its savings, experiences and knowledge gained in Sweden which offers innovations in terms of eco-friendly food packaging in Europe and which was elected as Europe's pilot area for practices, since 2007 as Turkey's first company with a Nordic Swan Ecolabel.

Our company produces paper plates, cups, cake baking capsules and other innovative products that the sector needs!

Human values such as quality, determination to produce products not harming the environment and human health, keeping our words in terms of delivery date and standards for our customers form the basis of our company mission.

PRODUCTION&DESIGN

Multipak focuses on each job specifically with its use of eco-friendly raw materials, customer-specific solutions and creative sense of design.

OUR BRANDS



Foliodream.



SWAN PROCESS

What is the SWAN label?

SWAN is the official ecolabel of the nordic countries and it is equivalent to the EU ecolabel.

Objective of SWAN

It aims to contribute to the studies for a sustainable life.

Its vision is to support a society maintaining the current conditions in order to meet the needs of the future generations. Therefore, it is significant for the consumer to prefer products with the SWAN and EU Ecolabel.

How does the SWAN process work?

A good or service is inspected from raw material to waste and the criteria are constantly challenged. Miljömarkning Sverige AB has been assigned by the government to take responsibility for the Swan and EU ecolabel in Sweden. These responsibilities include preparing the criteria, inspection and licensing the brands that are entitled to have this label.

What are the criteria for having a SWAN Ecolabel?

Many criteria regarding non-use of environmentally hazardous substances, air emission, water and soil, energy and resource usage, waste management should be fulfilled properly. Life cycle and holistic point of view are the key concepts of the SWAN process.

What is the difference of products with SWAN Ecolabel?

The brands with this label
* have a perspective of life cycle.
* have to fulfill the challenging environmental criteria being updated consistently.



Disposable
3047 0012

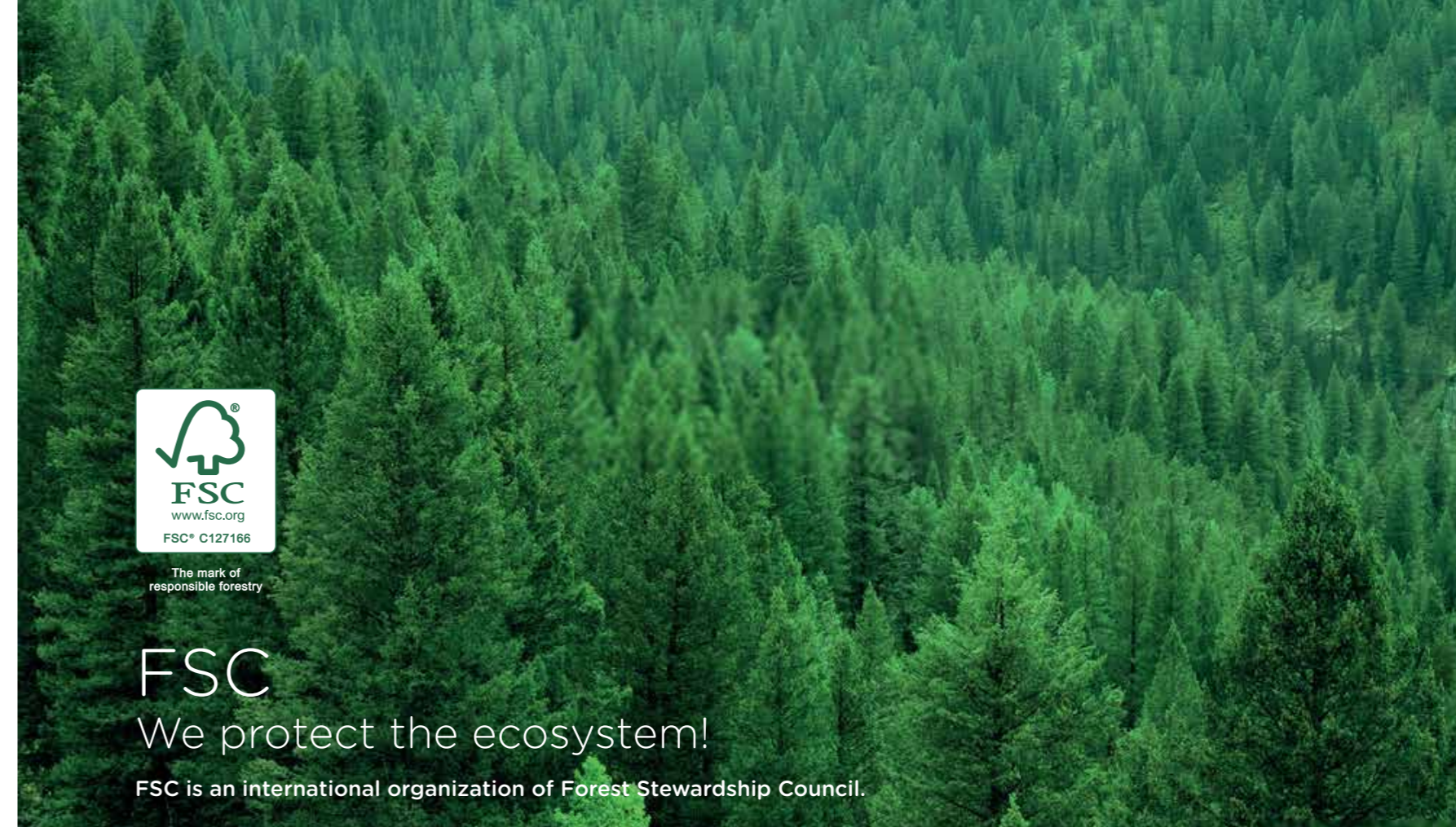

Working for a sustainable forest management, FSC carries out activities to determine and manage the international standards for proper usage of forestry products, and to provide independent compliance inspection for institution.

Thanks to this certificate, as Multipak, we carry out activities in accordance with the standards including all the processes, starting from supplying the forestry products to the delivery for consumers, and we work for a sustainable future.

Objective of FSC Certificate

To obtain wood and other forestry products without harming the forest productivity, biological diversity and ecological processes,

To carry out all the activities for profit in forests in a way not disturbing the ecosystem and society balance,

To provide systems enabling the society to benefit from forests and forestry products in the long term, but also supporting the sustainable usage of such products to have them involved in the long-term management plans.

COMPOST

What taken from nature comes back to nature!

100% soluble biodegradable compost products are produced in a way that they can be regained to nature by degrading in a short term. Products, the raw materials of which are cellulose, semi-cellulose and lignin, contribute to the protection of water resources and nature as well as human health by degrading thanks to the microorganism in nature.



INSPIRED BY
NATURE!

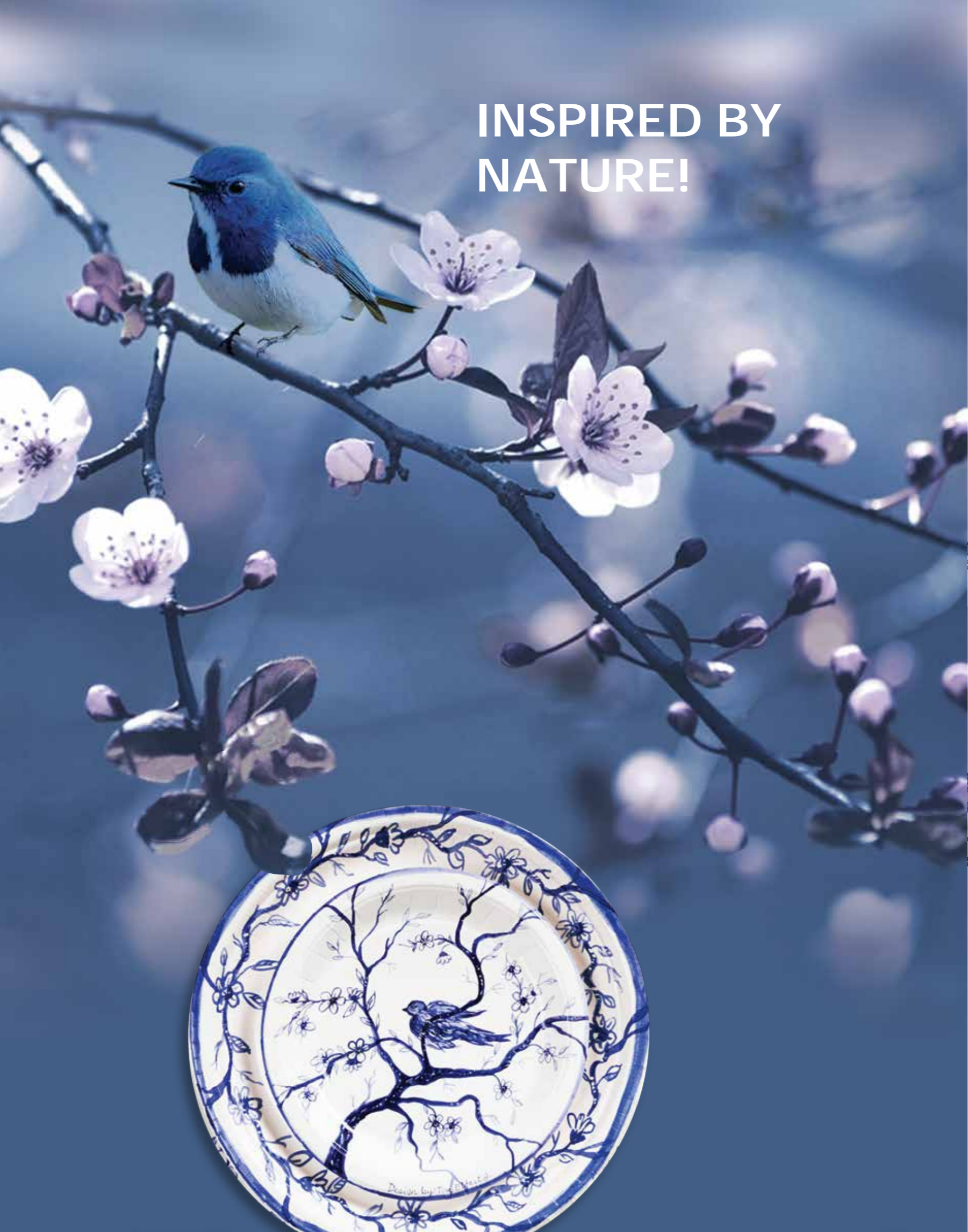

PLATES

While making life easier with our disposable plates,
first we have permission
from nature.



Basic

We enrich simplicity.

- Eco-friendly
- Recyclable
- Healthy

x2 Double-Floor

Offers endurance and strength thanks to its double-floor thick structure.

- Eco-friendly
- Recyclable
- Healthy
- Suitable for microwave

Customized
designs,
extraordinary
tables



By Tina Elfaat



SETS

This structure is made of
renewable resources.

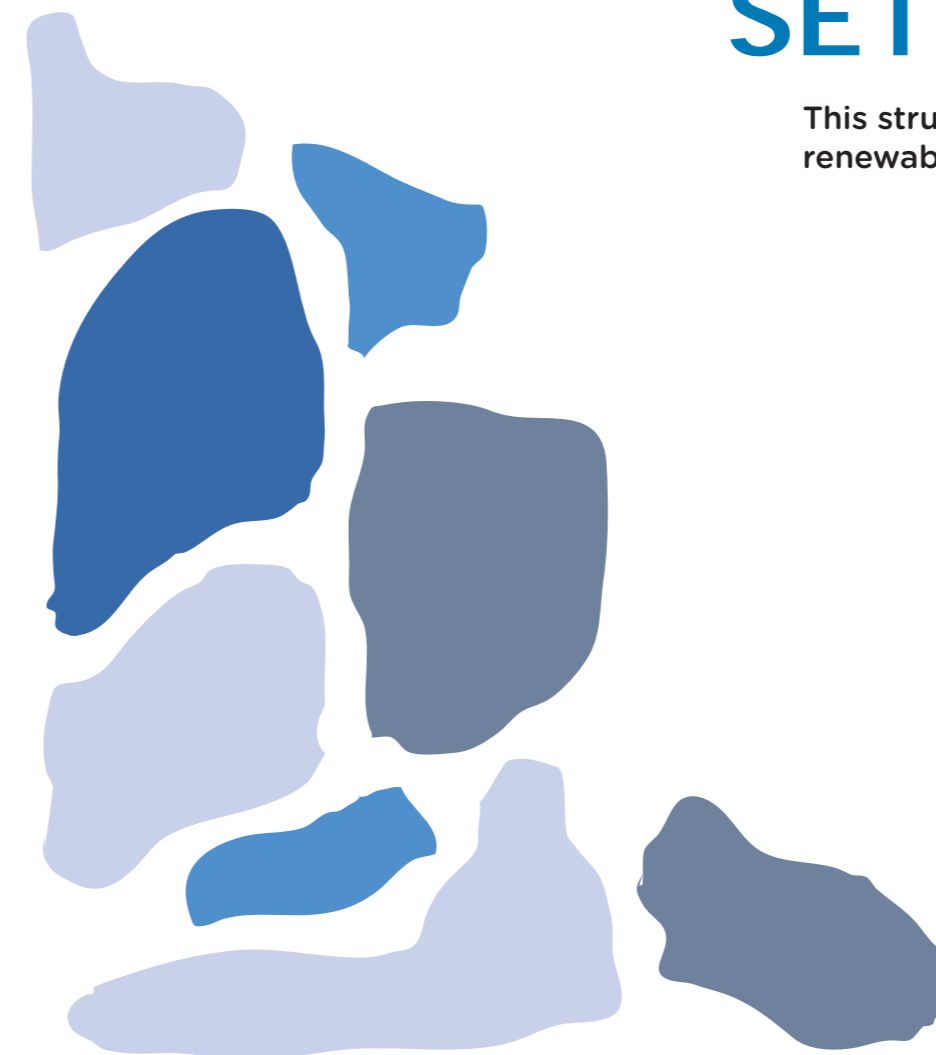



Art

We believe that various beauties will arise in every detail where art touches life.

We created an impressive world by collaborating with different designers for Multipak Art Series.



By Tina Elgast

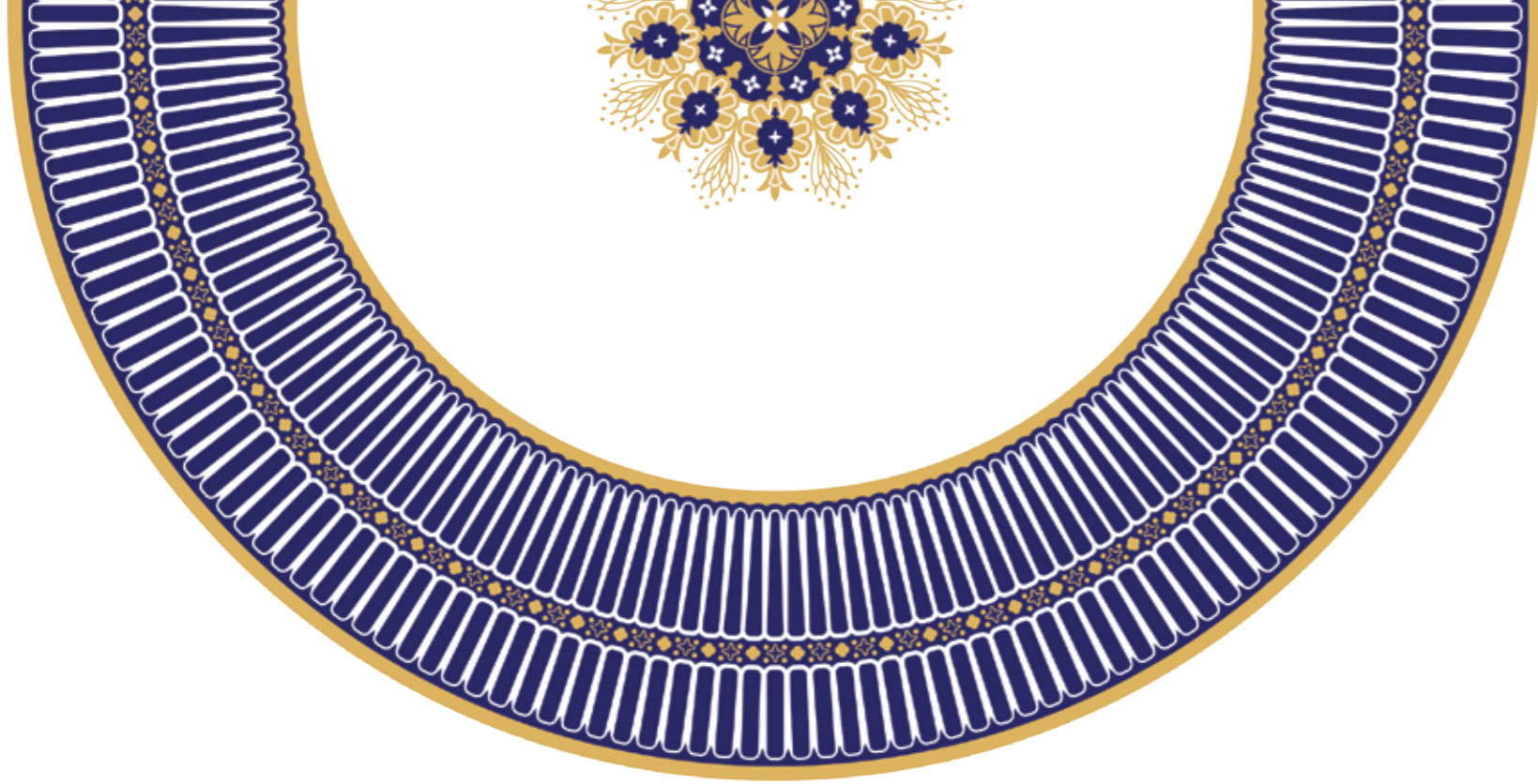

Impact

We offer aesthetic solutions by combining functionality and endurance.



For customized Multipak products
www.multipak.com.tr

Sparkling guests of crowded
new year's tables...



Event

As we think that the paper plates and cups you use in your most special days, events and birthday parties should also be special for you, we color up your events with the fun designs and wide range of the Multipak Event series.





Colorful elements of birthday parties...



Essentials of
theme parties...



For customized Multipak products
www.multipak.com.tr

CUPS

Our distinct designs and sense of production by using renewable resources bring us into the forefront.

This cup is
**100%
biodegradable.**

Healthy
Practical
Durable



Turkey's one
and only
Swan Nordic
licensed
products



Paper cups with superior durability provide heat insulation that prevents your drinks from condensing.

Being produced in desired size and design, our cups are made of recyclable raw materials.

Mikado Papercups Series





BAKING CAPSULES

You will be delighted in your
kitchens with our products
designed for you to bake tasty
muffins.



For customized Multipak products
www.multipak.com.tr

CAKE BAKING MOLDS

We design customized disposable cake baking molds in different forms so that you can enjoy your cakes.

Now it is
more fun to be
in the kitchen...





**DOUBLE
WALL
CUP**



**SALAD
BOWL**





Take Away

Having designed for fast moving consumer goods industry adopted by the world, our stylish, hygienic and durable Multipak products suitable for takeaway are with you in every moment of life!



Accompany you in every moment of life!



Ackforma

You will enjoy taste and practicality together with Multipak products suitable for microwave and oven. We offer practical solutions for both takeaway foods and your kitchen by means of its heat-resisting structure and raw material suitable for food contact.



Quality Introduction

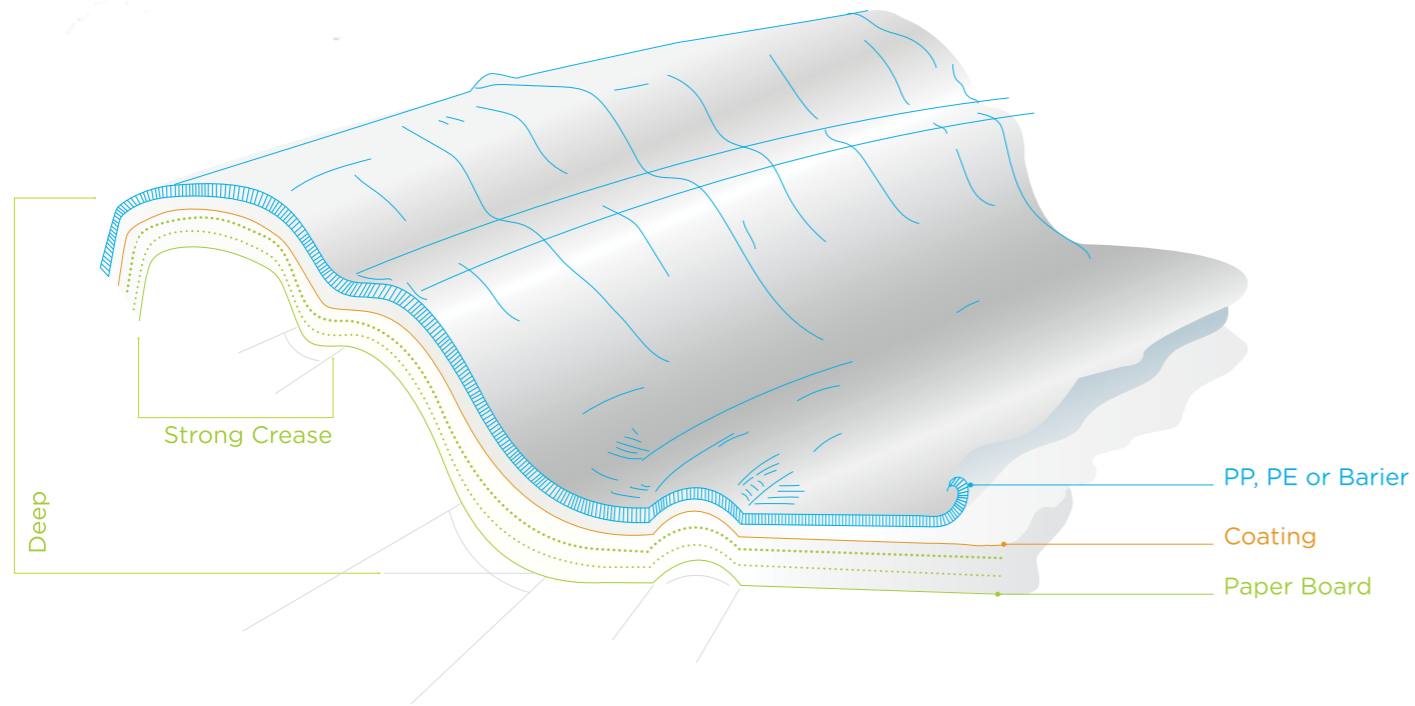
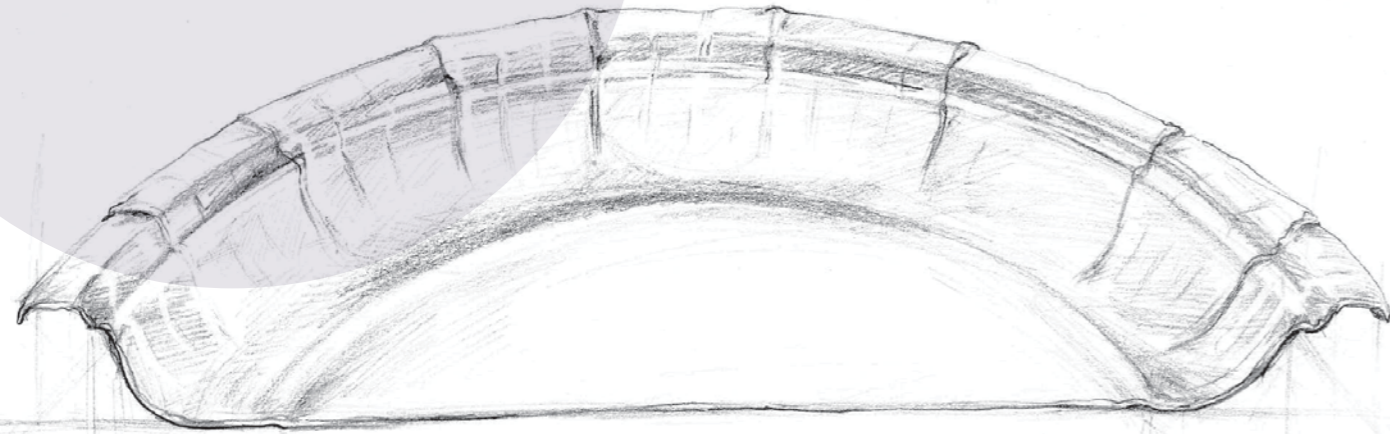

Rounded Plates

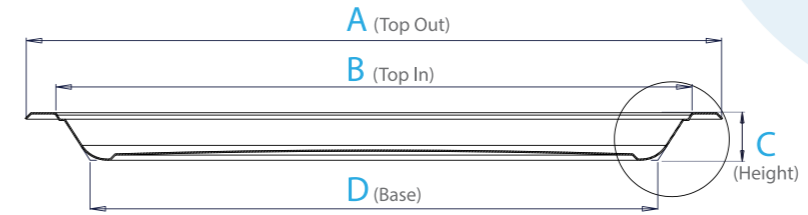

Products Infographic

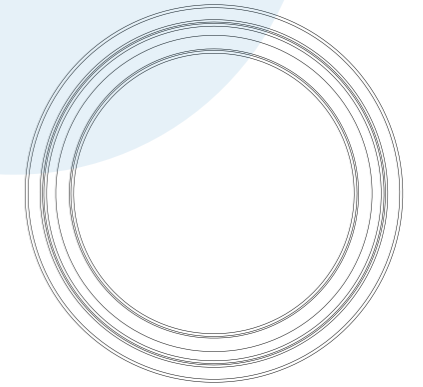

Ø 180 mm

A Top Out : 180 mm
B Top In : 155 mm
C Height : 12 mm
D Base : 120 mm

Ø 210 mm

A Top Out : 210 mm
B Top In : 195 mm
C Height : 15 mm
D Base : 145 mm

Ø 225 mm

A Top Out : 225 mm
B Top In : 203 mm
C Height : 15 mm
D Base : 157 mm

Ø 250 mm

A Top Out : 250 mm
B Top In : 224 mm
C Height : 19 mm
D Base : 195 mm

Ø 270 mm

A Top Out : 270 mm
B Top In : 247 mm
C Height : 18,5mm
D Base : 224 mm

New Flat Plates

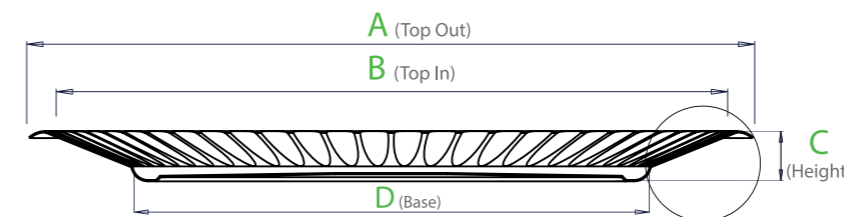

Products Infographic

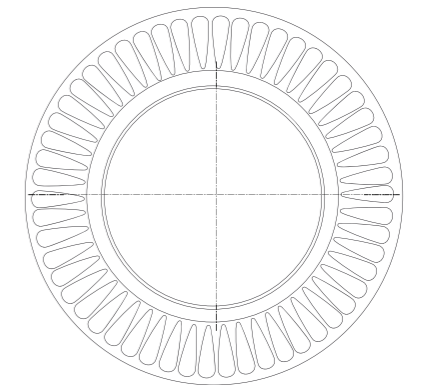

Ø 145 mm

A Top Out : 145 mm
B Top In : 135 mm
C Height : 13 mm
D Base : 89 mm

Ø 190 mm

A Top Out : 190 mm
B Top In : 175 mm
C Height : 18 mm
D Base : 117 mm

Ø 230 mm

A Top Out : 230 mm
B Top In : 215 mm
C Height : 18 mm
D Base : 154 mm

Ø 260 mm

A Top Out : 260 mm
B Top In : 255 mm
C Height : 18 mm
D Base : 187 mm

Rectangular Plates

- A1 Dış genişlik
- A2 Alt genişlik
- B1 İç genişlik
- B2 Alt iç genişlik
- C1 Yükseklik
- C2 Yükseklik
- D1 İç Taban
- D2 Dış Taban

Serving Plates

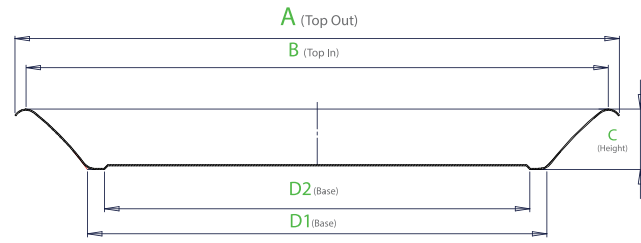

Products Infographic

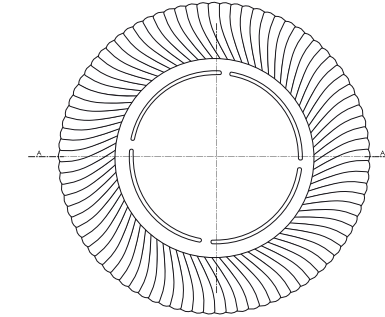
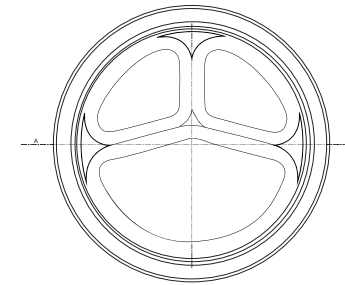
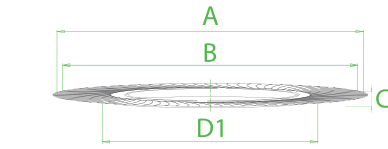
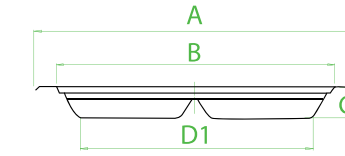
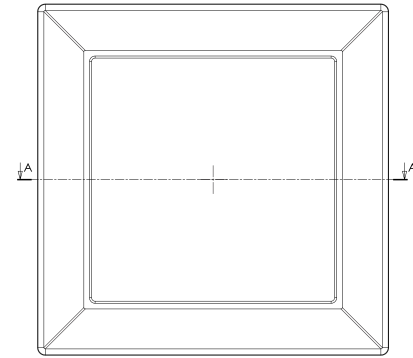

170 x 170 mm

A Top Out : 202 mm
B Top In : 185 mm
C1 Height : 14 mm
D1 Base : 145 mm
D2 Base : 125 mm

180 x 180 mm

A Top Out : 180 mm
B Top In : 166 mm
C1 Height : 25 mm
D1 Base : 127 mm
D2 Base : 119 mm

225 x 225 mm

A Top Out : 225 mm
B Top In : 220 mm
C1 Height : 21 mm
D1 Base : 145 mm
D2 Base : 154 mm

260 x 260 mm

A Top Out : 265 mm
B Top In : 250 mm
C1 Height : 10 mm
D1 Base : 170 mm
D2 Base : 125 mm

280 x 280 mm

A Top Out : 280 mm
B Top In : 175 mm
C1 Height : 15 mm
D1 Base : 171 mm
D2 Base : 161 mm

Ø 260 mm

A : 260 mm
B : 222 mm
C : 26 mm
D1 : 190 mm

Ø 310 mm

A : 310 mm
B : 295 mm
C : 10 mm
D1 : 270 mm

Deep Plates

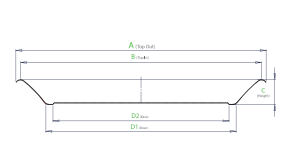
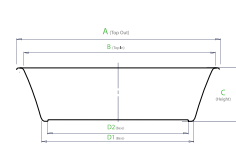
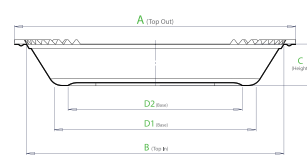
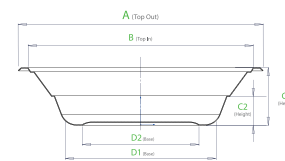
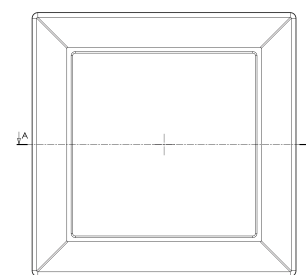
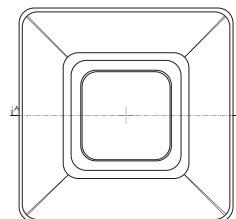
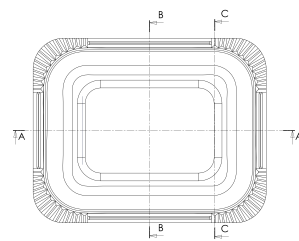
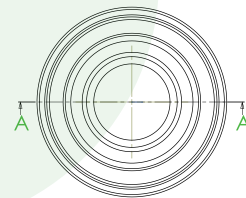

Ø 180 mm

A Top Out : 180 mm
B Top In : 174 mm
C1 Height : 42 mm
C2 Height : 21 mm
D1 Base : 110 mm
D2 Base : 85 mm

190 x 160 mm

A Top Out : 202 mm
B Top In : 185 mm
C1 Height : 33 mm
D1 Base : 145 mm
D2 Base : 125 mm

170 x 170 mm

A Top Out : 170 mm
B Top In : 155 mm
C1 Height : 44 mm
D1 Base : 105 mm
D2 Base : 76 mm

250 x 250 mm

A Top Out : 250 mm
B Top In : 240 mm
C1 Height : 25 mm
D1 Base : 190 mm
D2 Base : 184 mm

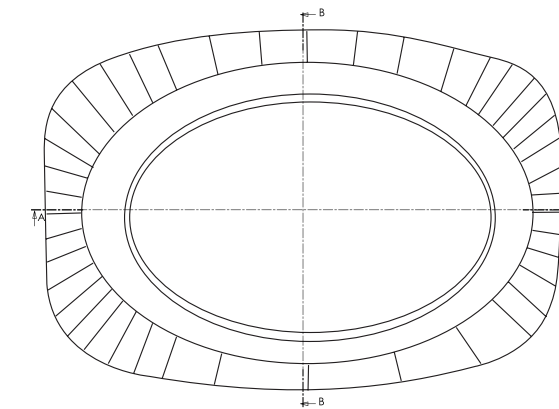
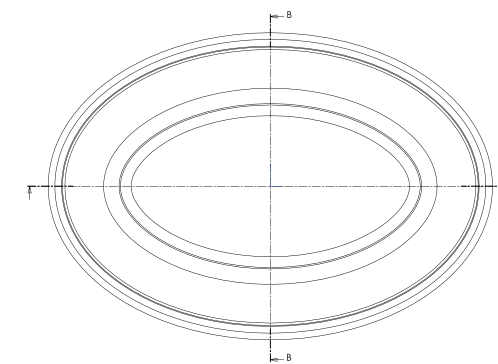
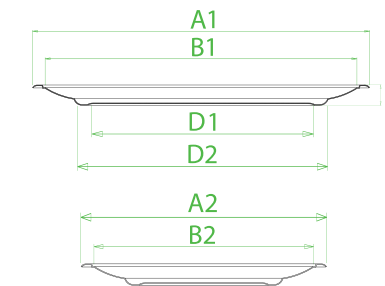
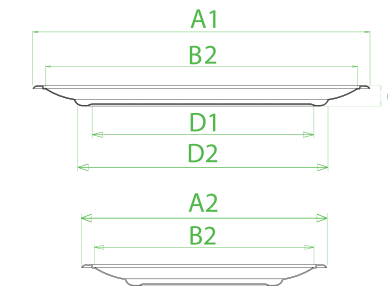

280 x 400 mm

A1 : 398 mm
A2 : 275 mm
B1 : 368 mm
B2 : 251 mm
C : 20 mm
D1 : 145 mm
D2 : 268 mm

465 x 321 mm

A1 : 465 mm
A2 : 312 mm
B1 : 400 mm
B2 : 260 mm
C : 23 mm
D1 : 320 mm
D2 : 350 mm

Cups

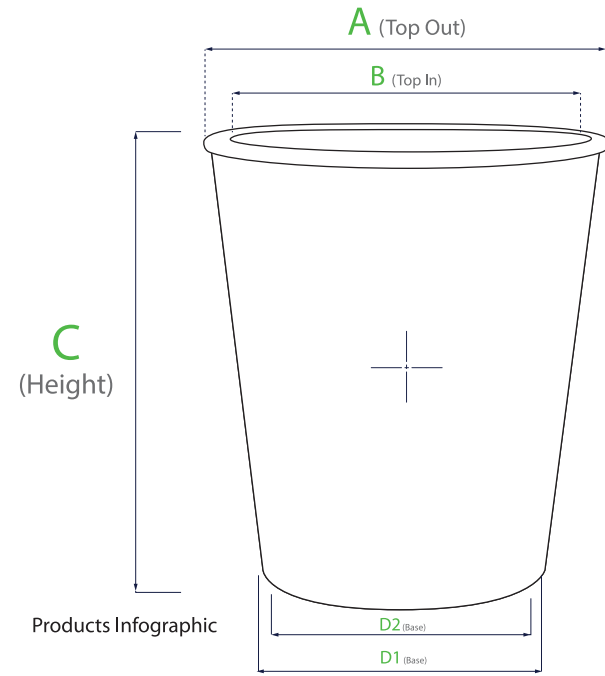

Products Infographic

4 OZ / 100 ML

A Top Out: 65 mm
B Top In : 56 mm
C Height : 600 mm
D1 Base : 44 mm
D2 Base : 42 mm

7 OZ / 200 ML

A Top Out: 72 mm
B Top In : 69 mm
C Height : 680 mm
D1 Base : 52 mm
D2 Base : 49 mm

8 OZ / 237 ML

A Top Out: 80 mm
B Top In : 74 mm
C Height : 920 mm
D1 Base : 56 mm
D2 Base : 54 mm

12 OZ / 355 ML

A Top Out: 89 mm
B Top In : 85 mm
C Height : 120 mm
D1 Base : 60 mm
D2 Base : 57 mm

16 OZ / 450 ML

A Top Out: 89 mm
B Top In : 85 mm
C Height : 136 mm
D1 Base : 60 mm
D2 Base : 63 mm

Salad Bowl

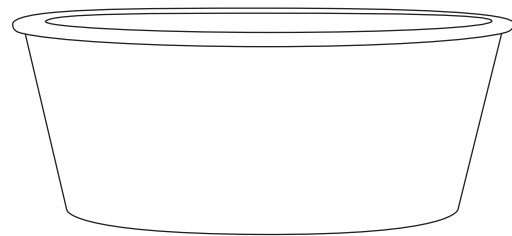

230 ML

A Top Out : 89 mm
B Top In : 85 mm
C Height : 120 mm
D1 Base In : 57 mm
D2 Base Out : 60 mm

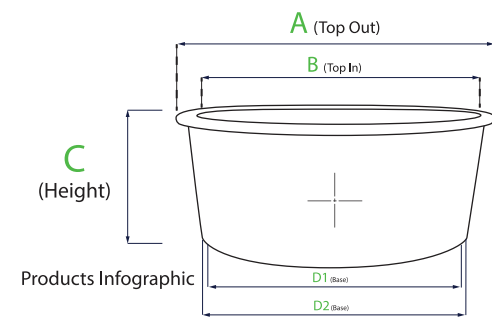

Products Infographic

Muffin Cups

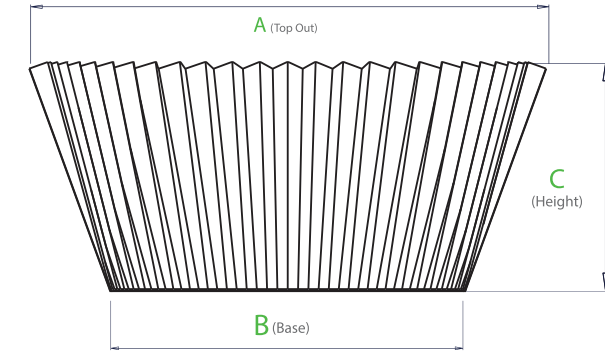

Products Infographic

28 x14 mm

A Top Out: 54 mm
B1x2 Top In: 40x60mm
C Height : 14 mm
D Base : 28 mm

18 x14 mm

A Top Out: 26 mm
B Base : 18 mm
C Height : 14 mm

20 x15 mm

A Top Out: 32 mm
B Base : 20 mm
C Height : 15 mm

35 x 20 mm

A Top Out: 55 mm
B Base : 35 mm
C Height : 20 mm

35 x 22 mm

A Top Out: 52 mm
B Base : 35 mm
C Height : 22 mm

40 x 30 mm

A Top Out: 55 mm
B Base : 40 mm
C Height : 30 mm

50 x 25 mm

A Top Out: 70 mm
B Base : 50 mm
C Height : 25 mm

50 x 30 mm

A Top Out: 73 mm
B Base : 50 mm
C Height : 30 mm

50 x 33 mm

A Top Out: 72 mm
B Base : 50 mm
C Height : 33 mm

60 x 40 mm

A Top Out: 75 mm
B Base : 60 mm
C Height : 40 mm

60 x 20 mm

A Top Out: 75 mm
B Base : 60 mm
C Height : 20 mm

60 x 26 mm

A Top Out: 77 mm
B Base : 60 mm
C Height : 26 mm

50 x 35 mm

A Top Out: 75 mm
B Base : 50 mm
C Height : 35 mm

65 x 45 mm

A Top Out: 93 mm
B Base : 65 mm
C Height : 45 mm

90 x 25 mm

A Top Out: 100 mm
B Base : 90 mm
C Height : 25 mm



50 x 75 mm

A Top Out: 50 mm
B Base : 50 mm
C Height : 75 mm

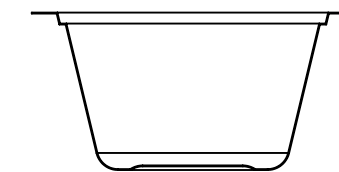

50 x 43 mm

A Top Out: 88 mm
B Base : 50 mm
C Height : 43 mm

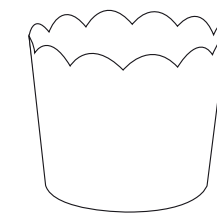

54 x 54 mm

A Top Out: 75 mm
B Base : 54 mm
C Height : 54 mm

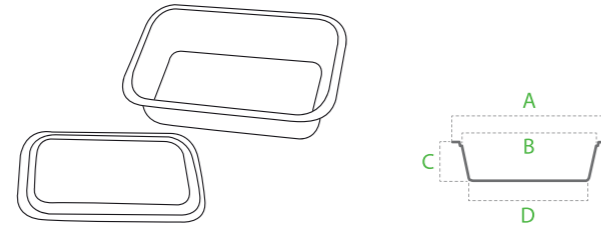

500 ml / (Lid) 1625

A : 150 x 120 mm
B : 136 x 106 mm
C : 41 mm
D : 114.1 x 84.1 mm

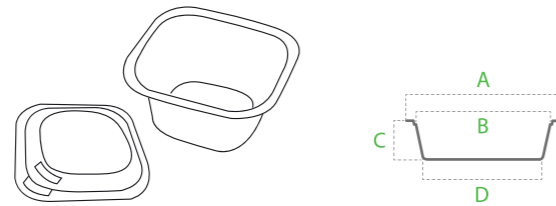

700 ml / (Lid) 1627

A : 142 x 142 mm
B : 128 x 128 mm
C : 70 mm
D : 92.7 x 92.7 mm

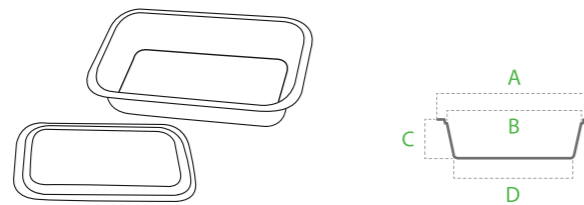

800 ml / (Lid) 1628

A : 215 x 145 mm
B : 201 x 131 mm
C : 42 mm
D : 178.6 x 108.6 mm

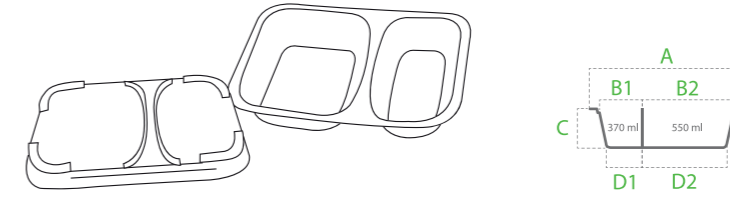

920 ml / (Lid) 1622

A : 227 x 178 mm
B1 : 86 x 162 mm
B2 : 120 x 162 mm
C : 38 mm
D1 : 58.4 x 134.4 mm
D2 : 92.4 x 134.4 mm

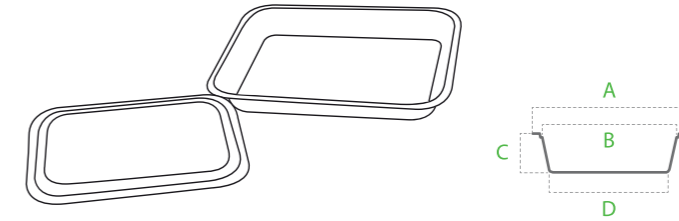

1170 ml / (Lid) 1632

A : 240 x 190 mm
B : 226 x 176 mm
C : 38 mm
D : 178.6 x 152.5 mm

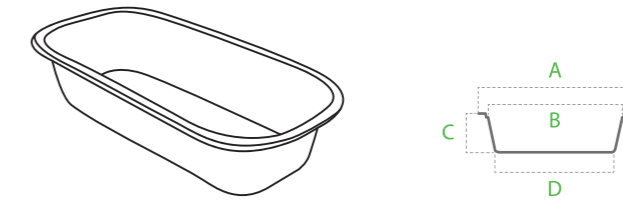

1200 ml / Kek Pişirme Kalıbı

A : 264 (g) x 129 mm
B : 245 (g) x 110 mm
C : 60 mm
D : 215 (g) x 80 mm

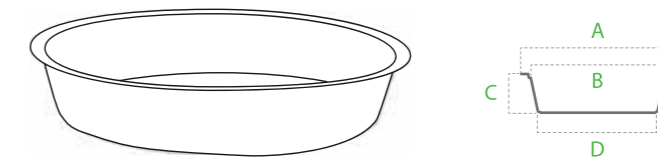

2340 ml / Kek Pişirme Kalıbı

A : 280 mm
B : 263 mm
C : 50 mm
D : 238 mm



**MULTIPAK AMBALAJ ve
GIDA SAN. TİC. A.Ş.**

Yazıbaşı Mahallesi,
Batıbeton Caddesi
No:10/1, 35875 Yazıbaşı
Torbali, İzmir / Türkiye

Tel. + 90 232 853 7495
Faks. + 90 232 853 7016

info@multipak.com.tr
www.multipak.com.tr